

User's Manual

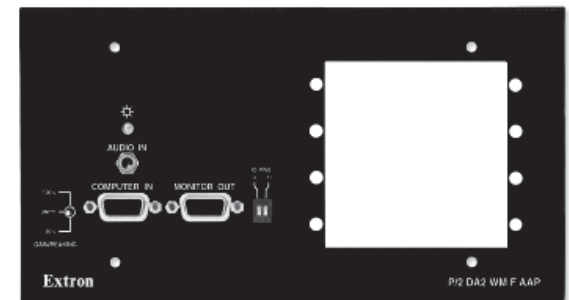
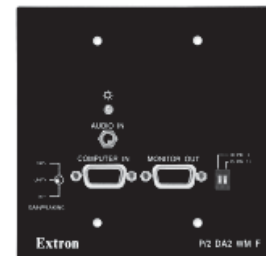

P/2 DA2 WM F, WM EC F, P/2 DA2 D, and AAP models

Distribution Amplifiers

Extron USA - West Headquarters +800.633.9876 <small>Inside USA / Canada Only</small> +1.714.491.1500 +1.714.491.1517 FAX	Extron USA - East +800.633.9876 <small>Inside USA / Canada Only</small> +1.919.863.1794 +1.919.863.1797 FAX	Extron EMEA +800.3987.6673 <small>Inside Europe Only</small> +31.33.453.4040 +31.33.453.4050 FAX	Extron Asia +800.7339.8766 <small>Inside Asia Only</small> +65.6383.4400 +65.6383.4664 FAX	Extron Japan +81.3.3511.7655 +81.3.3511.7656 FAX	Extron China +400.883.1568 <small>Inside China Only</small> +86.21.3760.1568 +86.21.3760.1566 FAX	Extron Middle East +971.4.2991800 +971.4.2991880 FAX
--	--	---	---	---	--	---

Precautions

Safety Instructions • English



This symbol is intended to alert the user of important operating and maintenance (servicing) instructions in the literature provided with the equipment.



This symbol is intended to alert the user of the presence of uninsulated dangerous voltage within the product's enclosure that may present a risk of electric shock.

Caution

Read Instructions • Read and understand all safety and operating instructions before using the equipment.

Retain Instructions • The safety instructions should be kept for future reference.

Follow Warnings • Follow all warnings and instructions marked on the equipment or in the user information.

Avoid Attachments • Do not use tools or attachments that are not recommended by the equipment manufacturer because they may be hazardous.

Consignes de Sécurité • Français



Ce symbole sert à avertir l'utilisateur que la documentation fournie avec le matériel contient des instructions importantes concernant l'exploitation et la maintenance (réparation).



Ce symbole sert à avertir l'utilisateur de la présence dans le boîtier de l'appareil de tensions dangereuses non isolées posant des risques d'électrocution.

Attention

Lire les instructions • Prendre connaissance de toutes les consignes de sécurité et d'exploitation avant d'utiliser le matériel.

Conservér les instructions • Ranger les consignes de sécurité afin de pouvoir les consulter à l'avenir.

Respecter les avertissements • Observer tous les avertissements et consignes marqués sur le matériel ou présentés dans la documentation utilisateur.

Eviter les pièces de fixation • Ne pas utiliser de pièces de fixation ni d'outils non recommandés par le fabricant du matériel car cela risquerait de poser certains dangers.

Sicherheitsanleitungen • Deutsch



Dieses Symbol soll den Benutzer auf wichtige Anleitungen zur Bedienung und Wartung (Instandhaltung) in der Dokumentation hinweisen, die im Lieferumfang dieses Gerätes enthalten ist.



Dieses Symbol soll den Benutzer darauf aufmerksam machen, daß im Inneren des Gehäuses dieses Produktes gefährliche Spannungen, die nicht isoliert sind und die einen elektrischen Schock verursachen können, herrschen.

Achtung

Lesen der Anleitungen • Bevor Sie das Gerät zum ersten Mal verwenden, sollten Sie alle Sicherheits- und Bedienungsanleitungen genau durchlesen und verstehen.

Aufbewahren der Anleitungen • Die Sicherheitsanleitungen sollten aufbewahrt werden, damit Sie später darauf zurückgreifen können.

Befolgen der Warnhinweise • Befolgen Sie alle Warnhinweise und Anleitungen auf dem Gerät oder in der Benutzerdokumentation.

Keine Zusatzgeräte • Verwenden Sie keine Werkzeuge oder Zusatzgeräte, die nicht ausdrücklich vom Hersteller empfohlen wurden, da diese eine Gefahrenquelle darstellen können.

Instrucciones de seguridad • Español



Este símbolo se utiliza para advertir al usuario sobre instrucciones importantes de operación y mantenimiento (o cambio de partes) que se desean destacar en el contenido de la documentación suministrada con los equipos.



Este símbolo se utiliza para advertir al usuario sobre la presencia de elementos con voltaje peligroso sin protección aislante, que puedan encontrarse dentro de la caja o alojamiento del producto, y que puedan representar riesgo de electrocución.

Precaución

Leer las instrucciones • Leer y analizar todas las instrucciones de operación y seguridad, antes de usar el equipo.

Conservar las instrucciones • Conservar las instrucciones de seguridad para futura consulta.

Obedecer las advertencias • Todas las advertencias e instrucciones marcadas en el equipo o en la documentación del usuario, deben ser obedecidas.

Evitar el uso de accesorios • No usar herramientas o accesorios que no sean específicamente recomendados por el fabricante, ya que podrían implicar riesgos.

Warning

Power sources • This equipment should be operated only from the power source indicated on the product. This equipment is intended to be used with a main power system with a grounded (neutral) conductor. The third (grounding) pin is a safety feature, do not attempt to bypass or disable it.

Power disconnection • To remove power from the equipment safely, remove all power cords from the rear of the equipment, or the desktop power module (if detachable), or from the power source receptacle (wall plug).

Power cord protection • Power cords should be routed so that they are not likely to be stepped on or pinched by items placed upon or against them.

Servicing • Refer all servicing to qualified service personnel. There are no user-serviceable parts inside. To prevent the risk of shock, do not attempt to service this equipment yourself because opening or removing covers may expose you to dangerous voltage or other hazards.

Slots and openings • If the equipment has slots or holes in the enclosure, these are provided to prevent overheating of sensitive components inside. These openings must never be blocked by other objects.

Lithium battery • There is a danger of explosion if battery is incorrectly replaced. Replace it only with the same or equivalent type recommended by the manufacturer. Dispose of used batteries according to the manufacturer's instructions.

Avertissement

Alimentations • Ne faire fonctionner ce matériel qu'avec la source d'alimentation indiquée sur l'appareil. Ce matériel doit être utilisé avec une alimentation principale comportant un fil de terre (neutre). Le troisième contact (de mise à la terre) constitue un dispositif de sécurité: n'essayez pas de le contourner ni de la désactiver.

Déconnexion de l'alimentation • Pour mettre le matériel hors tension sans danger, déconnectez tous les cordons d'alimentation de l'arrière de l'appareil ou du module d'alimentation de bureau (s'il est amovible) ou encore de la prise secteur.

Protection du cordon d'alimentation • Acheminer les cordons d'alimentation de manière à ce que personne ne risque de marcher dessus et à ce qu'ils ne soient pas écrasés ou pincés par des objets.

Réparation-maintenance • Faire exécuter toutes les interventions de réparation-maintenance par un technicien qualifié. Aucun des éléments internes ne peut être réparé par l'utilisateur. Afin d'éviter tout danger d'électrocution, l'utilisateur ne doit pas essayer de procéder lui-même à ces opérations car l'ouverture ou le retrait des couvercles risquent de l'exposer à de hautes tensions et autres dangers.

Fentes et orifices • Si le boîtier de l'appareil comporte des fentes ou des orifices, ceux-ci servent à empêcher les composants internes sensibles de surchauffer. Ces ouvertures ne doivent jamais être bloquées par des objets.

Lithium Batterie • Il a danger d'explosion s'il y a un remplacement incorrect de la batterie. Remplacer uniquement avec une batterie du même type ou d'un type équivalent recommandé par le constructeur. Mettre au reut les batteries usagées conformément aux instructions du fabricant.

Vorsicht

Stromquellen • Dieses Gerät sollte nur über die auf dem Produkt angegebene Stromquelle betrieben werden. Dieses Gerät wurde für eine Verwendung mit einer Hauptstromleitung mit einem geerdeten (neutralen) Leiter konzipiert. Der dritte Stift oder Kontakt ist für einen Erdschluß, und stellt eine Sicherheitsfunktion dar und sollte nicht umgangen oder außer Betrieb gesetzt werden.

Stromunterbrechung • Um das Gerät auf sichere Weise vom Netz zu trennen, sollten Sie alle Netzkabeln aus der Rückseite des Gerätes oder aus dem Desktop-Strommodul (falls dies möglich ist) oder aus der Wandsteckdose ziehen.

Schutz des Netzkabels • Netzkabel sollten stets so verlegt werden, daß sie nicht im Weg liegen und niemand darauf treten kann oder Objekte darauf- oder unmittelbar dagegengestellt werden können.

Wartung • Alle Wartungsmaßnahmen sollten nur von qualifiziertem Servicepersonal durchgeführt werden. Im Inneren des Gerätes sind keine Teile enthalten, die vom Benutzer gewartet werden können. Zur Vermeidung eines elektrischen Schocks versuchen Sie in keinem Fall, dieses Gerät selbst zu warten, da beim Öffnen oder Entfernen der Abdeckungen die Gefahr eines elektrischen Schlags oder andere Gefahren bestehen.

Schlitze und Öffnungen • Wenn das Gerät Schlitze oder Löcher im Gehäuse aufweist, dienen diese zur Vermeidung einer Überhitzung der empfindlichen Teile im Inneren. Diese Öffnungen dürfen niemals von anderen Objekten blockiert werden.

Litium-Batterie • Explosionsgefahr, falls die Batterie nicht richtig ersetzt wird. Ersetzen Sie nur durch diegleiche oder einen vergleichbaren Batterietyp, der auch vom Hersteller empfohlen wird. Entsorgung der verbrauchten Batterien bitte gemäß den Herstelleranweisungen.

Advertencia

Alimentación eléctrica • Este equipo debe conectarse únicamente a la fuente/tipo de alimentación eléctrica indicada en el equipo. El desenchufar todos los cables de equipo debe provenir de un sistema de distribución general con conductor neutro a tierra. La tercera pata (puesta a tierra) es una medida de seguridad, no puentearia ni eliminaria.

Desconexión de alimentación eléctrica • Para desconectar con seguridad la acometida de alimentación eléctrica al equipo, desenchufar todos los cables de alimentación en el panel trasero del equipo, o desenchufar el módulo de alimentación (si fuera independiente), o desenchufar el cable del receptáculo de la pared.

Protección del cables de alimentación • Los cables de alimentación eléctrica se deben instalar en lugares donde no sean pisados ni apretados por objetos que se puedan apoyar sobre ellos.

Reparaciones/mantenimiento • Solicitar siempre los servicios técnicos de personal calificado. En el interior no hay partes a las que el usuario deba acceder. Para evitar riesgo de electrocución, no intentar personalmente la reparación/ mantenimiento de este equipo, ya que al abrir o extraer las tapas puede quedar expuesto a voltajes peligrosos u otros riesgos.

Ranuras y aberturas • Si el equipo posee ranuras o orificios en su caja/alojamiento, es para evitar el sobrecalentamiento de componentes internos sensibles. Estas aberturas nunca se deben obstruir con otros objetos.

Batería de litio • Existe riesgo de explosión si esta batería se coloca en la posición incorrecta. Cambiar esta batería únicamente con el mismo tipo (o su equivalente) recomendado por el fabricante. Desachar las baterías usadas siguiendo las instrucciones del fabricante.

Extron's Warranty

Extron Electronics warrants this product against defects in materials and workmanship for a period of three years from the date of purchase. In the event of malfunction during the warranty period attributable directly to faulty workmanship and/or materials, Extron Electronics will, at its option, repair or replace said products or components, to whatever extent it shall deem necessary to restore said product to proper operating condition, provided that it is returned within the warranty period, with proof of purchase and description of malfunction to:

USA, Canada, South America, and Central America:

Extron Electronics
1001 East Ball Road
Anaheim, CA 92805, USA

Asia:

Extron Electronics, Asia
135 Joo Seng Road, #04-01
PM Industrial Bldg.
Singapore 368363

Europe, Africa, and the Middle East:

Extron Electronics, Europe
Beeldschermweg 6C
3821 AH Amersfoort
The Netherlands

Japan:

Extron Electronics, Japan
Kyodo Building
16 Ichibancho
Chiyoda-ku, Tokyo 102-0082
Japan

This Limited Warranty does not apply if the fault has been caused by misuse, improper handling care, electrical or mechanical abuse, abnormal operating conditions or non-Extron authorized modification to the product.

If it has been determined that the product is defective, please call Extron and ask for an Applications Engineer at (714) 491-1500 (USA), 31.33.453.4040 (Europe), 65.6383.4400 (Asia), or 81.3.3511.7655 (Japan) to receive an RA# (Return Authorization number). This will begin the repair process as quickly as possible.

Units must be returned insured, with shipping charges prepaid. If not insured, you assume the risk of loss or damage during shipment. Returned units must include the serial number and a description of the problem, as well as the name of the person to contact in case there are any questions.

Extron Electronics makes no further warranties either expressed or implied with respect to the product and its quality, performance, merchantability, or fitness for any particular use. In no event will Extron Electronics be liable for direct, indirect, or consequential damages resulting from any defect in this product even if Extron Electronics has been advised of such damage.

Please note that laws vary from state to state and country to country, and that some provisions of this warranty may not apply to you.

安全须知 • 中文



这个符号提示用户该设备用户手册中的操作和维护说明。



这个符号警告用户该设备机壳内暴露的危险电压，有触电危险。

注意

阅读说明书 • 用户使用该设备前必须阅读并理解有安全和使用说明。

保存说明书 • 用户应保存安全说明书以备将来使用。
遵守警告 • 用户应遵守产品和用户指南上的所有安全和操作说明。

避免追加 • 不要使用该产品厂商没有推荐的工具或追加设备，以避免危险。

警告

电源 • 该设备只能使用产品上标明的电源。设备必用有地线供电系统供电。第三条线（地线）是安设施，不能不用或跳过。

拔掉电源 • 为安全地从设备拔掉电源，请拔掉所有后备或桌面电源的电源线，或任何接到市电系统电源线。

电源线保护 • 妥善布线，避免被踩踏，或重物挤压。

维护 • 所有维修必须由认证的维修人员进行。设备部没有用户可以更换的零件。为避免出现触电危险不要自己试图打开设备盖子维修该设备。

通风孔 • 有些设备机壳上有通风槽或孔，它们是用防止机内敏感元件过热。不要用任何东西挡住通风孔。

锂电池 • 不正确的更换电池会有爆炸的危险。必须使与厂家推荐的相同或相近型号的电池。按照生产厂的议处理废弃电池。

FCC Class A Notice

This equipment has been tested and found to comply with the limits for a Class A digital device, pursuant to part 15 of the FCC Rules. These limits are designed to provide reasonable protection against harmful interference when the equipment is operated in a commercial environment. This equipment generates, uses and can radiate radio frequency energy and, if not installed and used in accordance with the instruction manual, may cause harmful interference to radio communications. Operation of this equipment in a residential area is likely to cause harmful interference, in which case the user will be required to correct the interference at his own expense.

NOTE *This unit was tested with shielded cables on the peripheral devices. Shielded cables must be used with the unit to ensure compliance.*

Table of Contents

Chapter 1 • Introduction	1-1
About the P/2 DA2 WM F/EC F, AAP and D Models	1-2
Features	1-2
Chapter 2 • Controls and Installation	2-1
Front and Rear Panels	2-2
Front faceplate	2-2
P/2 DA2 WM F/EC F rear panel	2-4
P/2 DA2 D rear panel	2-5
Installing the P/2 DA2 WM F/EC F	2-7
Easy setup procedure	2-7
Installing the mud ring bracket	2-8
Cabling	2-10
Connecting audio output	2-11
Installing architectural adapter plates	2-12
P/2 DA2 WM F wall mount installation	2-14
P/2 DA2 WM EC F Euro Channel installation	2-15
Setting the DIP switches	2-15
Setting the internal jumpers	2-16
Installing the P/2 DA2 D	2-17
Preparing the site and installing the wall box	2-17
Mounting the distribution amplifier	2-18
Replacing the faceplate	2-20
P/2 DA2 D application example	2-20
Appendix • Specifications, Dimensions, Parts, and Templates	A-1
Specifications	A-2
Dimensions	A-7
P/2 DA2 WM F faceplate dimensions	A-7
P/2 DA2 WM F AAP faceplate dimensions	A-8
P/2 DA2 D faceplate dimensions	A-9
Part and Accessories	A-10
Included parts	A-10
Cables	A-10
Mud ring mounting brackets	A-10
Optional architectural adapter plates	A-11

Table of Contents, cont'd

Templates	A-15
P/2 DA2 WM F mounting template	A-15
P/2 DA2 WM F AAP mounting template	A-16
P/2 DA2 D mounting template	A-17



P/2 DA2 WM/EC/D/AAP Series

Chapter One

Introduction

About the P/2 DA2 WM F/ EC F, AAP, and D Models

Features

All trademarks mentioned in this manual are the properties of their respective owners.

68-463-02 **Rev. C**
09 08

About the P/2 DA2 WM F/EC F, AAP, and D Models

The P/2 DA2 WM F/F EC, AAP, and D models are one input, two output, high resolution VGA/XGA distribution amplifiers with audio. With a video bandwidth of 300 MHz, these distribution amplifiers are compatible with VGA, SVGA, VESA, XGA, and SXGA graphics cards, monitors, projectors, and LCD panels. The D model features Decora® faceplates and trim.

For audio, the P/2 DA2 WM F/EC F and D feature a 3.5 mm female jack for input and a 3.5 mm captive screw connector for balanced or unbalanced output. The D model features a DIP switch for selecting stereo or dual mono output.

The P/2 DA2 WM F is the wallmount version and the P/2 DA2 WM EC F is the Euro Channel version. The P/2 DA2 WM F AAP and the P/2 DA2 WM EC F AAP are the same base products, but with AAP faceplates added. These plates are a convenient method of providing various connectors for most audio and video applications.

Features

2-color power/signal LED — When the interface is on, the power/signal LED lights amber. When the interface is on and a signal is present, the LED lights green.

Gain/peak control— Compensates for signal degradation caused by long cable lengths.

Stereo audio — Front panel audio input jack and a 3.5 mm captive screw output connector on the rear panel.

Buffered local monitor output — 15-pin HD female connector

Computer video input — 15-pin HD female connector

Wall mountable (WM model) — Self-contained enclosure provides for convenient wall mounting.

Euro Channel mountable (EC model) — This model mounts easily in the Euro Channel raceway

Optional architectural adapter plates — The P/2 DA2 WM F AAP may be user-configured with up to four Architectural Adapter Plates (three for the EC AAP version). These adapter plates provide a selection of pass-through signal connectors for various audio and video requirements.



P/2 DA2 WM/EC/D/AAP Series

Chapter Two

Controls and Installation

Front and Rear Panels

Installing the P/2 DA2 WM F/EC F

Installing the P/2 DA2 D

Front and Rear Panels

Front faceplate

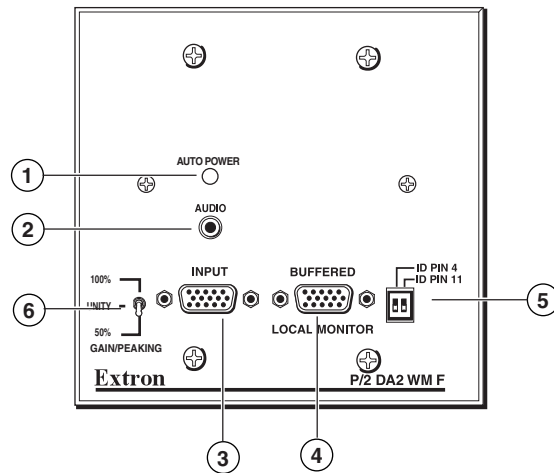

P/2 DA2 WM F faceplate features

NOTE Both WM F and WM EC F models have the same front and rear panel connectors and features.

- ① **2-color power/signal LED** — lights amber to indicate power on only; lights green to indicate power on with video signal present.
- ② **Audio input jack** — 3.5 mm stereo input
- ③ **VGA input connector** — HD 15-pin female analog video input connector
- ④ **Buffered local monitor output** — HD 15-pin female for output to a local monitor
- ⑤ **ID bit termination DIP switches** — provides proper ID bit termination for a laptop computer that is not attached to a local monitor. See “Setting the DIP switches” in this chapter.
- ⑥ **3-position gain/peaking switch** — compensates for cable capacitance and resistance due to long cable runs; position switch for best image on the output display device.

100% – increases the output signal level and adds 100% of the maximum peaking to the signal

Unity – output signal level is same as that of input with no added peaking

50% – increases the output signal level and adds 50% of the maximum peaking to the signal

NOTE If the edges of the image seem to exceed their boundaries, or if thin lines and sharp edges look thick and fuzzy, try changing the level/peak setting.

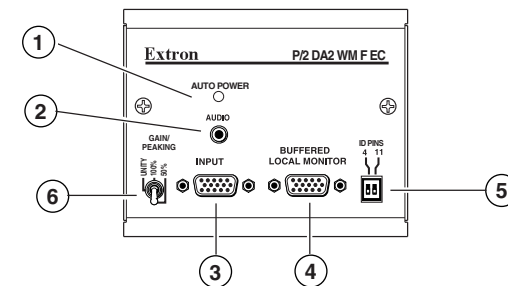

P/2 DA2 WM EC F faceplate features

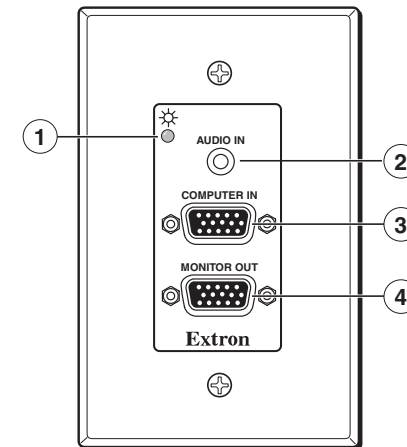

P/2 DA2 D faceplate features

P/2 DA2 WM F/EC F rear panel

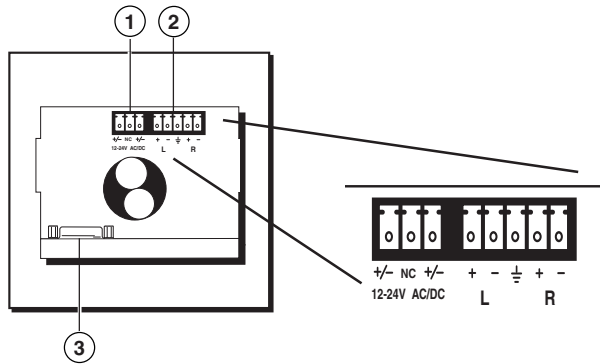

P/2 DA2 WM F/EC F rear connectors

NOTE Both WM F and WM EC F models have the same rear panel connectors.

- ① **Power input** — 12 - 24 VAC or DC (captive screw connector). The center pole contains no conductor. Connect the conductors to the outer two poles only.

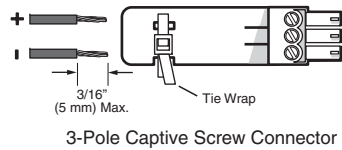

- ② **Audio output** — 3.5 mm captive screw stereo output
- ③ **VGA output** — HD 15-pin female analog video output connector

P/2 DA2 D rear panel

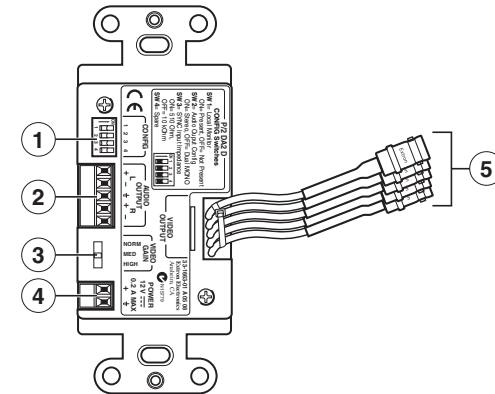
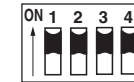

Figure 2-5 — P/2 DA2 D rear connectors

- ① **Configuration DIP switches** — The three DIP switches (plus one spare) configure the P/2 DA2 D, as shown in the table below.

NOTE The default DIP switch positions are set to On (up). Set these switches before installing the distribution amplifier in a wall.



Switch	Function	On (up)	Off (down)
SW1	local monitor (set ID bits 4 and 11)	monitor present	monitor not present
SW2	audio output configuration	stereo	dual mono
SW3	input sync impedance	510 ohms	10k ohms
SW4	spare	n/a	n/a

- ② **Audio output** — 3.5 mm captive screw stereo or dual mono output (DIP switch selectable, see switch SW 2 in ① above).

- ③ **Gain switch** — To compensate for cable resistance and capacitance, use a small screwdriver to slide this switch to select the level of video gain that yields the sharpest, smear-free picture.

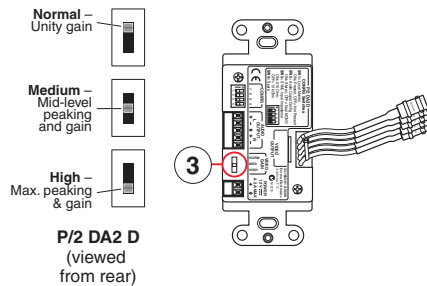

NOTE *Adjust the gain before installing the P/2 DA2 D into a wall, as the gain switch will be inaccessible after installation.*

- ④ **Power input** — Connect the included 12 VDC external power supply into the 2-pole, 3.5 mm captive screw connector. Be careful to observe the correct polarity.

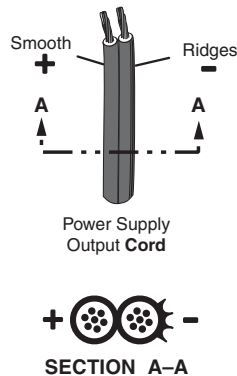

- ⑤ **Video output** — BNC connectors for RGBHV output.

Installing the P/2 DA2 WM F/EC F

Easy setup procedure

The wall-mounted P/2 DA2 WM F kit consists of the faceplate/distribution amplifier assembly and a mounting bracket that mounts in a wall opening and to which the faceplate assembly is attached. The P/2 DA2 WM EC F kit consists of the faceplate/distribution amplifier assembly that mounts in the Euro Channel raceway.

- ① For wall mounting only: Using the mounting template provided in the appendix as a guide, carefully cut a mounting hole through the wall where the mounting bracket is to be installed.
- ② For wall mounting only: Install the mud ring mounting bracket using the supplied screws and mounting clips. Refer to the section "Installing a mud ring bracket" for further details.
- ③ Before connecting any cables, power off all equipment. If the optional architectural adapter plate (AAP) is being installed, please refer to "Installing architectural adapter plates" in this chapter.
- ④ The rear connectors are the same for both WM F and WM F EC models. Connect the VGA output cable to the 15-pin HD female output connector. To prevent installation debris or objects from entering the opening in the sheet metal just above this VGA connector, use masking tape to temporarily cover this opening. Remove this tape after installation is completed. Next, if there is audio output, connect the audio output cable to the captive screw connector. Finally, connect the power cable to the power input connector. Refer to the "Cabling" and "Connecting audio" sections of this chapter.
- ⑤ Before attaching the faceplate assembly to the wall mounting bracket/Euro Channel, attach the computer video cable to the 15-pin HD female input connector on the faceplate. Next, a local monitor may be connected to the 15-pin HD female buffered local monitor output connector on the faceplate. Finally, for audio input, connect the audio cable to the faceplate's 3.5 mm audio input jack. Refer to the "Cabling" and "Connecting audio" sections of this chapter. For Euro Channel applications, refer to the "Euro Channel installation" section.

Controls and Installation, cont'd

- 6 Power up all of the input and output devices.
- 7 The image should now display on screen. If it does not, double check steps 3 through 6 and make adjustments as needed. Refer to the section "Setting the DIP switches" in this chapter.
- 8 For the P/2 DA2 WM F, attach the P/2 DA2 WM F to the wall mounting bracket (see "Installing the mud ring bracket").

For the P/2 DA2 WM EC F, attach the P/2 DA2 WM F EC to the Euro Channel (see "P/2 DA2 WM EC F Euro Channel installation").

Installing the mud ring bracket

1. Once the proper wall location for mounting the distribution amplifier has been determined, cut an opening in the wall using the proper mounting template found in the appendix.
2. Carefully cut away the mounting surface material inside the traced template lines.
3. Test the fit of the mud ring. The doglegs should fit easily into the hole and the flat portion should rest flush against the wall. See the note in the following illustration.
4. Rotate all doglegs **inward**.
5. Insert the mud ring into the hole.
6. Tighten all of the dogleg screws until the doglegs clamp the mud ring to the mounting surface. Do not overtighten.

Standard mud rings only: If you are going to screw the mud ring to the surface, rather than using the detachable doglegs, mark the four surface mounting screw holes at the corners of the mud ring.

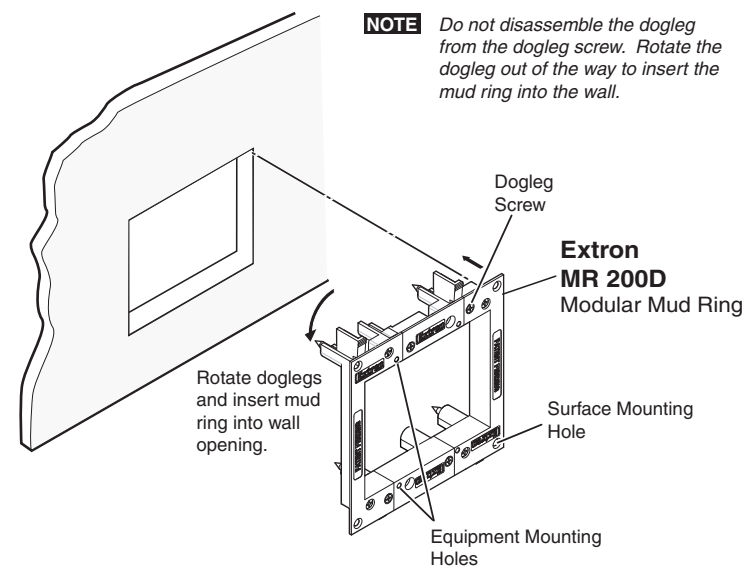

Installing a mud ring bracket

Cabling

The P/2 DA2 WM F cabling diagram below shows how to connect input and output devices to the distribution amplifier's front panel. The P/2 DA2 WM EC F model has identical connectors.

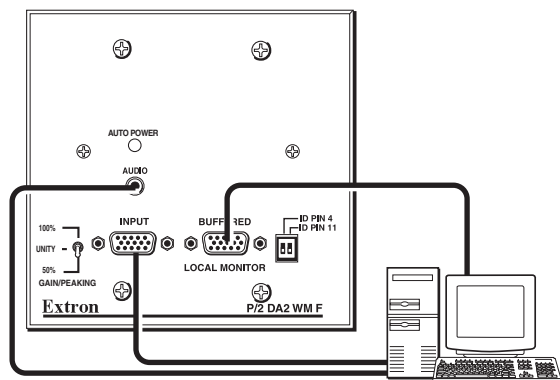

P/2 DA2 WM F cabling

1. Connect your display device to the 15-pin HD female video output VGA connector on the rear of the P/2 DA2 WM F/EC F.
2. For audio output, refer to the section "Connecting audio output" and connect the audio output cable to the 3.5 mm captive screw connector on the rear of the P/2 DA2 WM F/EC F.
3. Connect the power input cable to the rear power input connector of the P/2 DA2 WM F/EC F.
4. Connect the computer's video cable to the 15-pin HD female input cable on the distribution amplifier's faceplate.
5. If a local monitor is being used, connect the monitor to the 15-pin HD female buffered local monitor output on the faceplate.
6. For audio input, connect the input device into the front faceplate's 3.5 mm female audio jack.

Connecting audio output

Before connecting audio output, determine whether your audio system is unbalanced or balanced. Then, follow the instructions below to connect unbalanced audio, or the instructions for "Balanced audio" to connect balanced audio.

CAUTION *Wiring the audio incorrectly may damage the audio output circuits.*

Unbalanced audio

To attach the P/2 DA2 WM F/EC F to an unbalanced audio system, do the following:

1. Attach the audio cable to an unbalanced speaker input connector (tip and sleeve).

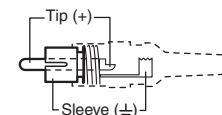

2. Attach the audio cable to the audio cable connector (Extron part number 10-319-10). Fasten the captive screws inside the audio cable connector.

Fastening captive screws



CAUTION

For unbalanced audio, connect the sleeve(s) to the ground contact. **DO NOT** connect the sleeve(s) to the negative (-) contacts.

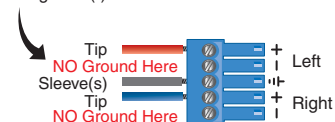

Unbalanced Output

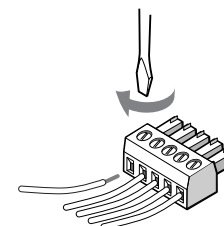

3. Slide the audio cable connector into the audio output connector on the interface.

Balanced audio

To attach the distribution amplifier to a balanced audio system, do the following:

1. Attach the audio cable to a balanced speaker input connector (tip, ring, and sleeve).

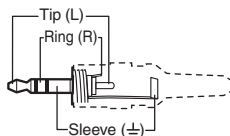

2. Attach the audio cable to the audio cable connector (Extron part number 10-319-10). Fasten the captive screws inside the audio cable connector as shown below.

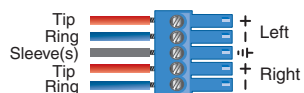

Balanced Output

3. Slide the audio cable connector into the audio output connector on the distribution amplifier.

Installing architectural adapter plates

The P/2 DA2 WM F AAP may have up to four optional adapter plates and the P/2 DA2 WM F AAP EC can have up to three adapter plates. The adapter plates provide a convenient method of adding various connectors for specific audio and video requirements. The adapter plates must be ordered separately and must be attached to the faceplate and cabled before attaching the WM F AAP model to the wall mount bracket or the EC F AAP model to the Euro Channel.

1. Insert the adapter plate captive screws through the front faceplate holes. Secure the adapter plate using the supplied washers and nuts.

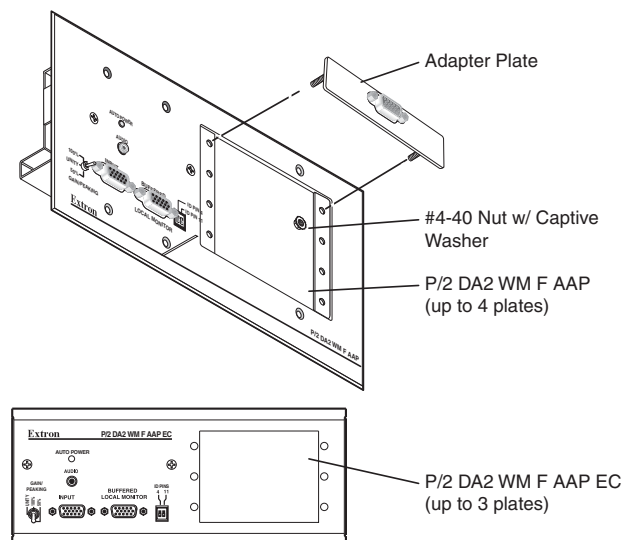

Installing adapter plates

2. Attach the output cables to the back side of the adapter plate. Some adapter plates may require that conductors be soldered to the connectors. Attach foil and braided shields to ground connections.

P/2 DA2 WM F wall mount installation

Once the input and output cables have been connected and the P/2 DA2 WM F has been successfully tested, the faceplate may be attached to the mounting bracket using the four supplied screws.

NOTE The center pole of the power input connector contains no conductor. Connect the conductors to the two outer poles only, exactly as shown here.

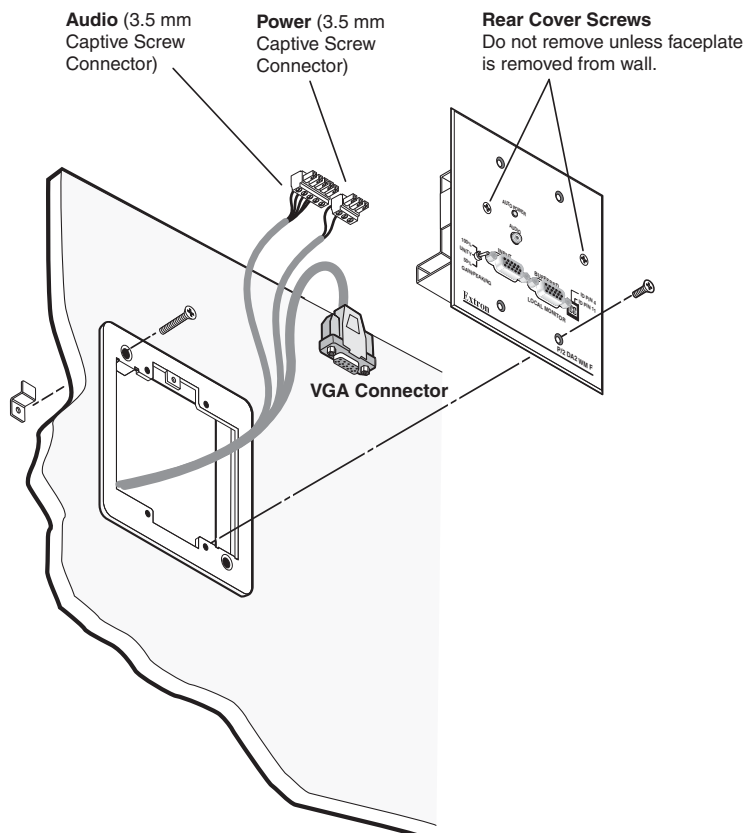
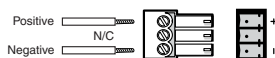

Wall mounting the P/2 DA2 WM F

P/2 DA2 WM EC F Euro Channel installation

Once the input and output cables have been connected and tested on the P/2 DA2 WM F EC, the distribution amplifier can be easily installed in the Euro Channel.

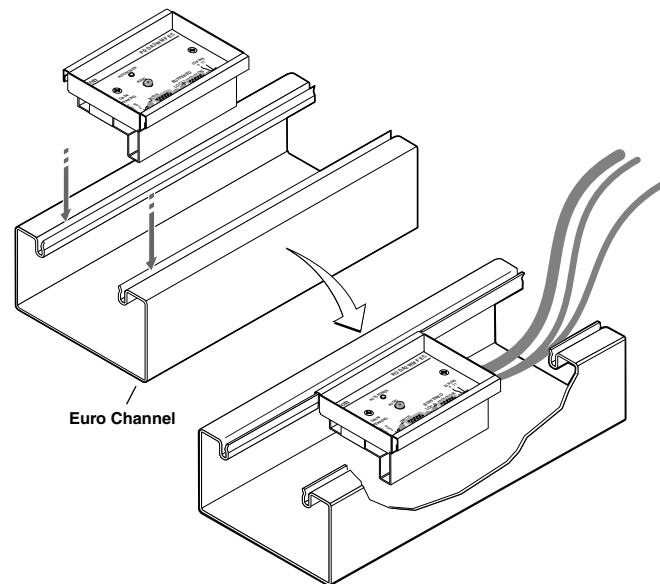

Euro Channel installation

Setting the DIP switches

Two sliding-type DIP switches can be found on the faceplate of the P/2 DA2 WM F/EC F.



To set the sliding-type DIP switches, slide the switch to the on/closed or off/open position.

The two DIP switches provide proper ID bit termination for a laptop computer that is not attached to a local monitor.

ID Pin 4 & ID Pin 11

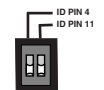

ON — Set both pins to On if you are using the P/2 DA2 WM F/EC F with a laptop computer that is not attached to a local monitor.

OFF — Set both pins to Off if you are attaching a local monitor to the P/2 DA2 WM F/EC F.

Setting the internal jumpers

The jumpers (J2 and J6) inside the distribution amplifier are set at the factory for output to a local monitor. However, you can direct output to a data display by resetting the jumpers. Follow these steps and the illustration below to change the jumper settings. In some instances where DDC communication is required between the display device and the computer's graphics card, pins 15 (J2) and 12 (J6) will carry that information.

CAUTION Changes to internal jumper settings must be performed only by authorized service personnel.

1. Disconnect the power cable, then disconnect the output and audio cables from the rear panel of the distribution amplifier. Next, remove the rear cover by removing the two front panel screws. See "P/2 DA2 F wall mount installation" in this chapter for screw locations.
2. Using a pair of tweezers or needle-nosed pliers, set jumpers J2 and J6, as shown below in figure 2-10.

CAUTION Be sure you are electrically grounded before touching any circuit board components.

- Connect pins 1 and 2 on both jumpers (factory default) to output to the 15-pin female local monitor connector on the front panel.

or

- Connect pins 2 and 3 on both jumpers to output to the rear 15-pin female output.

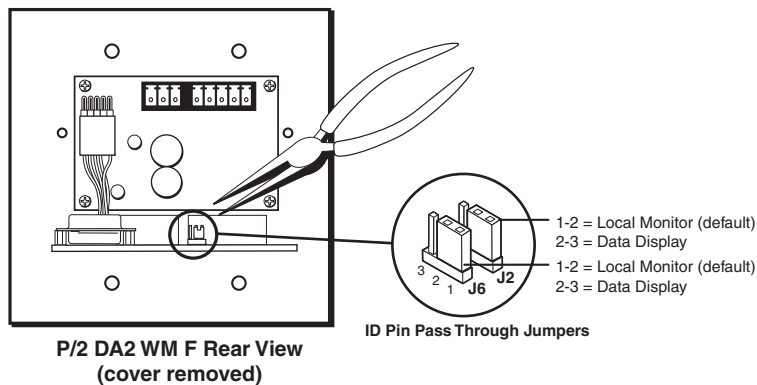

Setting the internal jumpers

3. Replace the rear cover and reconnect the output cable. Reconnect the power and/or audio cables.

Installing the P/2 DA2 D

The P/2 DA2 D is a wall-mounted product and can be mounted into an electrical wall box. These instructions include site preparation, wall box installation, and the mounting of the distribution amplifier in the wall box.

NOTE The P/2 DA2 D must be installed into an Underwriters Laboratories (UL) approved electrical wall box. The box is not included with the distribution amplifier; the installer is responsible for obtaining/installing the box.

Preparing the site and installing the wall box

Choose a location that allows cable runs without interference. Allow enough depth for both the wall box and the cables. You may need to install the cables into the wall or conduits before installing the distribution amplifier.

The distribution amplifier can be installed in a standard one-gang electrical wall box. The installation must conform to national and local electrical codes. A dimensional drawing and a cutout template of the distribution amplifier are provided in appendix A of this manual.

NOTE The cutout template of the P/2 DA2 D shown in appendix A is not full size. Pay attention to the measurements shown in the template.

1. Mark the guidelines for the opening on the wall.
 - If the distribution amplifier will be installed in a wall box, place the box against the installation surface and draw a line on it around the outside of the box.
 - If the distribution amplifier will be installed without a wall box (fastening it directly to the wall), measure and mark the surface for the cutout area indicated in the cutout template.
2. Cut out the material from the marked area.
3. Check the opening size by inserting the wall box (if used) or the distribution amplifier (if no box is used) into the opening. Enlarge or smooth the edges of the opening if needed.
4. Feed the cables through the wall box punch-out holes, and secure them with cable clamps to provide strain relief.
5. Insert the wall box into the opening, and attach it to the wall or stud using nails or screws. The front edge should be flush with the outer wall surface. See the following illustration.

Controls and Installation, cont'd

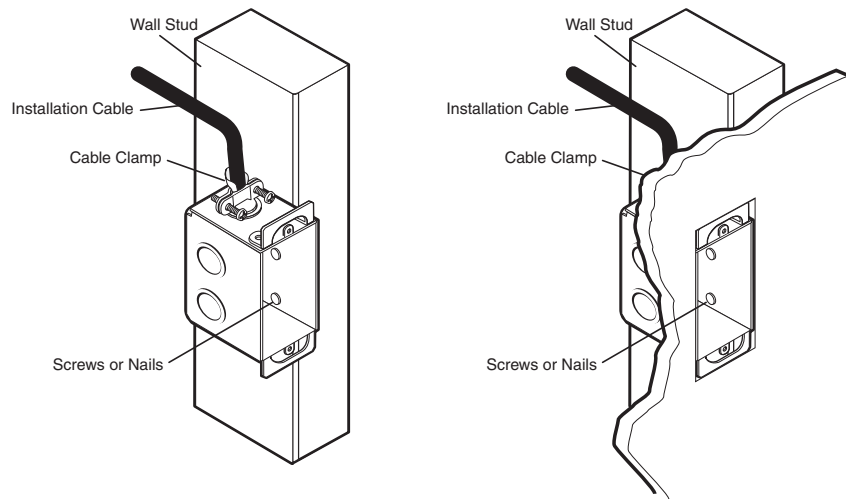

Attaching the wall box to a wall stud

If attaching the wall box to wood, use four #8 or #10 screws or 10-penny nails. A minimum of 1/2 inch (1.3 cm) of screw threads must penetrate the wood.

If attaching the wall box to metal studs, use four #8 or #10 self-tapping sheet metal screws or machine bolts with matching nuts.

Mounting the distribution amplifier

Before mounting the distribution amplifier and if it has not already been tested, test the system to make sure that the connections and settings are correct.

If the system is operating correctly, the distribution amplifier can be installed in the wall. Adjust the gain and set the DIP switches before fastening the distribution amplifier into the wall box. The controls and cables will be inaccessible after installation. See "Rear Panel Features and Operation" in this chapter for details about settings and adjustments.

Continue mounting the distribution amplifier by following the steps below.

1. Remove power from the distribution amplifier by disconnecting the power supply.
2. Place the distribution amplifier through the opening in the wall and into the wall box. Take care not to damage the output cable(s), which fit behind the distribution amplifier at the back of the wall box.

3. Mount the distribution amplifier to the wall box with machine screws, as shown in the following illustration.

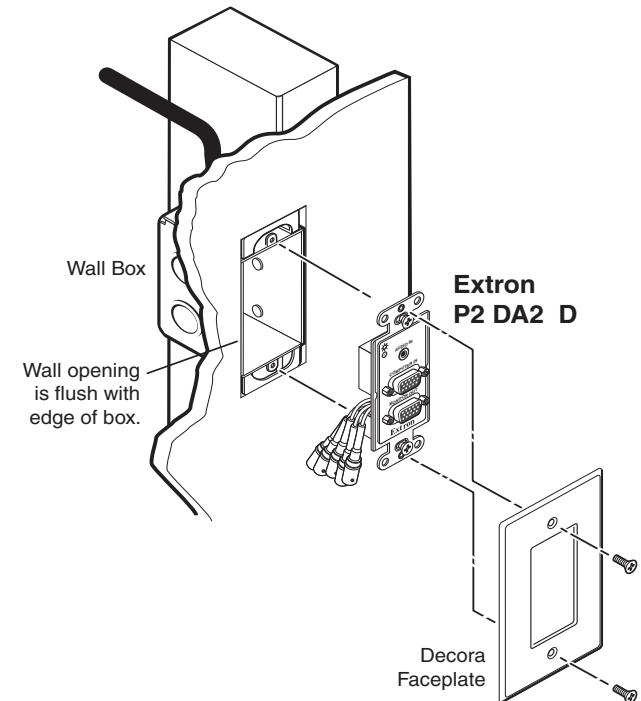

Mounting the distribution amplifier to the wall box

4. Attach the Decora cover plate to the line driver, as shown in the previous illustration.
5. Reconnect the power supply and restore power to the equipment.

Replacing the faceplate

The front faceplate is replaced by removing the two rear panel mounting screws, replacing the faceplate, then reattaching the two screws, as shown below.

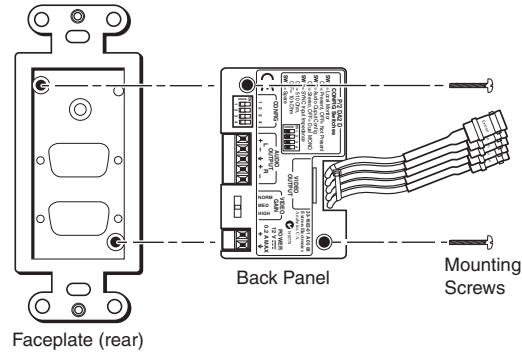

P/2 DA2 D application example

An example of the P/2 DA2 D installation is shown below.

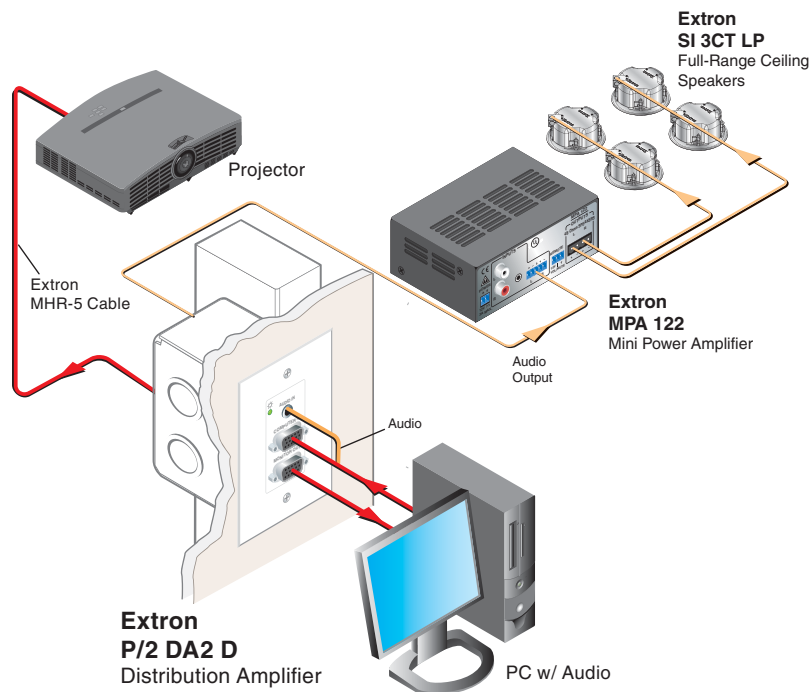

P/2 DA2 WM/EC/D/AAP Series

Appendix A

Specifications, Dimensions, Parts, and Templates

Specifications

Dimensions

Parts and Accessories

Templates

Specifications, Dimensions, and Parts

Specifications

Video

Gain

P/2 DA2 D	Main output: 0 dB, 0.6 dB, 1.2 dB, selectable Local monitor output: unity
P/2 DA2 WM F, P/2 DA2 WM F AAP	Switchable: 0 dB, +1.2 dB, +2.2 dB(0.7 V, 0.8 V, or 0.9 V when input is 0.7 V and the gain/peaking switch is set to Unity, 50%, or 100%, respectively)

Bandwidth

P/2 DA2 D	350 MHz (-3 dB)
P/2 DA2 WM F, P/2 DA2 WM F AAP	300 MHz (-3 dB)

NOTE ID bits can be terminated (pins 4 and 11) via a switch setting.

Video input

Number/signal type

P/2 DA2 D	1 VGA-QXGA RGBHV, RGBS, RGsB, RsGsBs, HDTV component video
P/2 DA2 WM F, P/2 DA2 WM F AAP	1 VGA-UXGA RGBHV, RGBS, RGsB, RsGsBs, HDTV component video

Connectors

Connectors	(1) female 15-pin HD
Nominal level	1.0 Vp-p for Y of component video 0.7 Vp-p for RGB and for R-Y and B-Y of component video
Minimum/maximum levels	Analog: 0.4 V to 1.4 Vp-p with no offset at unity gain
Impedance	75 ohms
Horizontal frequency	15 kHz to 135 kHz
Vertical frequency	30 Hz to 170 Hz
Return loss	<-38 dB @ 5 MHz
DC offset (max. allowable)	
P/2 DA2 D	±5 mV
P/2 DA2 WM F, P/2 DA2 WM F AAP	200 mV
Input coupling (P/2 DA2 D)	DC

Video output

Number/signal type

P/2 DA2 D	1 VGA-QXGA RGBHV, RGBS, RGsB, RsGsBs, HDTV component video main output 1 VGA-QXGA RGBHV, RGBS, RGsB, RsGsBs, HDTV component video local monitor output
P/2 DA2 WM F, P/2 DA2 WM F AAP	2 VGA-UXGA RGBHV, RGBS, RGsB, RsGsBs, HDTV component video (with adapter)

Connectors

P/2 DA2 D	
Main output	5 female BNC on 3" pigtails
Local monitor	1 female 15-pin HD
P/2 DA2 WM F, P/2 DA2 WM F AAP	(2) 15-pin HD female (1 display, 1 local monitor)
Nominal level	1.0 Vp-p for Y of component video 0.7 Vp-p for RGB and for R-Y and B-Y of component video
Minimum/maximum levels	Analog: 0.4 V to 1.4 Vp-p (follows input)
Impedance	75 ohms
Return loss (P/2 DA2 D)	<-38 dB @ 5 MHz P/2 DA2 WM F AAP <-40 dB @ 5 MHz
DC offset (P/2 DA2 D)	±5 mV with input at 0 offset

Sync

Input type	RGBHV, RGBS, RGsB, RsGsBs, bi-level and tri-level component video sync
Output type	RGBHV, RGBS, RGsB, RsGsBs, bi-level and tri-level component video sync
Input level	3.0 V to 5.0 Vp-p
Output level	0.3 Vp-p for component video (bi-level sync) 0.6 Vp-p for component video (tri-level sync) TTL: 5.0 Vp-p, unterminated for RGBHV, RGBS
Input impedance	510 ohms or 10k ohm, switch selectable

Specifications, Dimensions, Parts, cont'd

Output impedance

P/2 DA2 D	75 ohms
P/2 DA2 WM F, P/2 DA2 WM F AAP	40 ohms, typical

Max. propagation delay

P/2 DA2 D	60 ns
P/2 DA2 WM F, P/2 DA2 WM F AAP	18.8 ns

Max. rise/fall time 4 ns

Polarity Positive or negative (follows input)

Audio

Gain Unbalanced output: 0 dB; balanced output: +6 dB

Frequency response 20 Hz to 20 kHz, ± 0.05 dB

THD + Noise 0.03% @ 1 kHz at nominal level

S/N >90 dB at maximum output (unweighted)

Crosstalk (P/2 DA2 D) <-80 dB @ 1 kHz

Stereo channel separation (P/2 DA2 D) >80 dB @ 1 kHz

CMRR (P/2 DA2 D) >67 dB @ 20 Hz to 20 kHz

Audio input

Number/signal type 1 stereo, unbalanced

Connectors (1) 3.5 mm mini stereo jack (tip, ring, sleeve)

Impedance

P/2 DA2 D	>18k ohms unbalanced, DC coupled
P/2 DA2 WM F, P/2 DA2 WM F AAP	>5k ohms unbalanced, DC coupled

Nominal level -10 dBV (316 mVrms)

Maximum level

P/2 DA2 D	+10 dBV, (unbalanced) at 1% THD+N
P/2 DA2 WM F, P/2 DA2 WM F AAP	+8.5 dBu (unbalanced) at 1% THD+N

NOTE $0 \text{ dBu} = 0.775 \text{ Vrms}$, $0 \text{ dBV} = 1 \text{ Vrms}$, $0 \text{ dBV} \approx 2 \text{ dBu}$

Audio output

Number/signal type

P/2 DA2 D 1 stereo or dual mono (switch selectable), balanced/unbalanced

P/2 DA2 WM F, P/2 DA2 WM F AAP 1 stereo, balanced/unbalanced

Connectors (1) 3.5 mm direct insertion captive screw connector, 5 pole

Impedance 50 ohms unbalanced, 100 ohms balanced

Gain error (P/2 DA2 D) ± 0.5 dB channel to channel

Maximum level (Hi-Z) +15 dBu, balanced or unbalanced, at 1% THD+N

Maximum level (600 ohm) +9 dBm, balanced or unbalanced, at 1% THD+N

General

External power supply 100 VAC to 240 VAC, 50/60 Hz, external; to 12 VDC, 1 A (max.), regulated

Power input requirements 12 VDC, 0.2 A

Temperature/humidity Storage: -40 to +158 °F (-40 to +70 °C) / 10% to 90%, noncondensing
Operating: +32 to +122 °F (0 to +50 °C) / 10% to 90%, noncondensing

Cooling Convection, no vents

Mounting Wall or furniture mountable

Enclosure type

P/2 DA2 D	Metal faceplate and a plastic Decora® wall plate
P/2 DA2 WM F, P/2 DA2 WM F AAP	Metal

Enclosure dimensions

P/2 DA2 D

Faceplate 2.6" H* x 1.3" W x 0.1" D
(6.6 cm H* x 3.3 cm W x 0.3 cm D)
(Fits the opening in a 1 gang Decora faceplate. *Height is 3.8" [9.7 cm] including mounting tabs.)

Buffer 2.7" H x 1.8" W x 0.75" D*
(6.9 cm H x 4.6 cm W x 1.9 cm D*)
(*Depth excludes BNC connectors and cables.)

Specifications, Dimensions, and Parts, cont'd

P/2 DA2 WM F

Faceplate 4.5" H x 4.6" W x 0.1" D
(11.4 cm H x 11.7 cm W x 0.3 cm D)
(2 gang)

Box 2.6" H x 3.7" W x 1.6" D
(6.6 cm H x 9.4 cm W x 4.1 cm D)

P/2 DA2 WM F AAP

Faceplate 4.5" H x 8.3" W x 0.1" D
(11.4 cm H x 21.1 cm W x 0.3 cm D)
(4 gang)

Box 2.6" H x 3.7" W x 1.6" D
(6.6 cm H x 9.4 cm W x 4.1 cm D)

Product weight

P/2 DA2 D 0.2 lbs (0.1 kg)

P/2 DA2 WM F 0.4 lbs (0.2 kg)

P/2 DA2 WM F AAP 0.6 lbs (0.3 kg)

Shipping weight 2 lb (1 kg)

Vibration ISTA 1A in carton (International Safe Transit Association)

Listings UL, CUL

Regulatory compliance

Safety CE, C-tick, UL, CUL

EMI/EMC CE, FCC Class A, VCCI, C-tick, ICES

MTBF 30,000 hours

Warranty 3 years parts and labor

NOTE All nominal levels are at $\pm 10\%$.

NOTE Specifications are subject to change without notice.

Dimensions

Dimensions of the P/2 DA2 WM F and its AAP version are provided here for those who wish to make their own customized faceplates. The following diagrams are not drawn to scale.

NOTE All dimensions are given in inches.

P/2 DA2 WM F faceplate dimensions

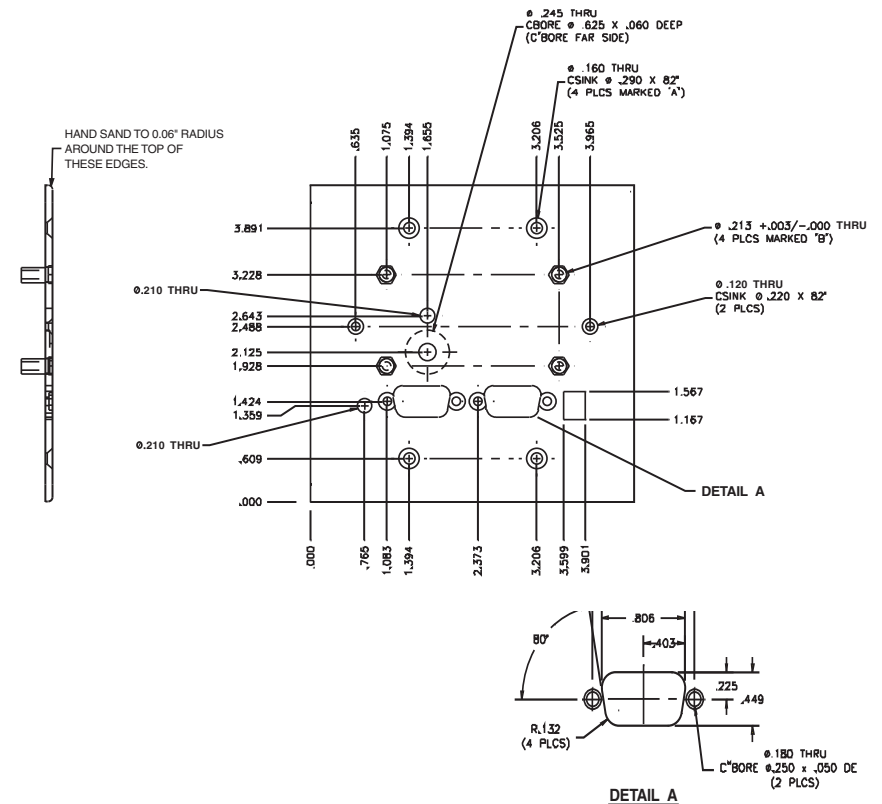

WM F model faceplate dimensions

P/2 DA2 WM F AAP faceplate dimensions

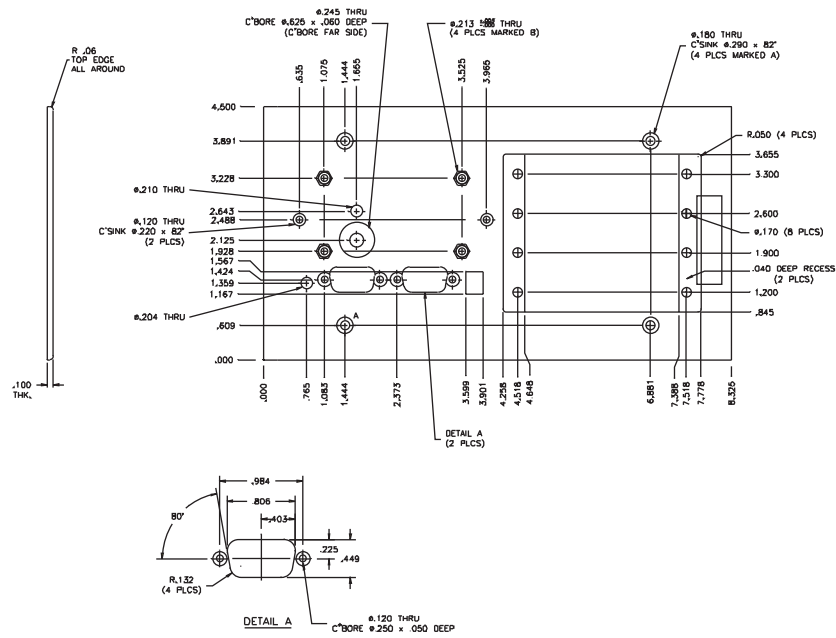

WM F AAP model faceplate dimensions

P/2 DA2 D faceplate dimensions

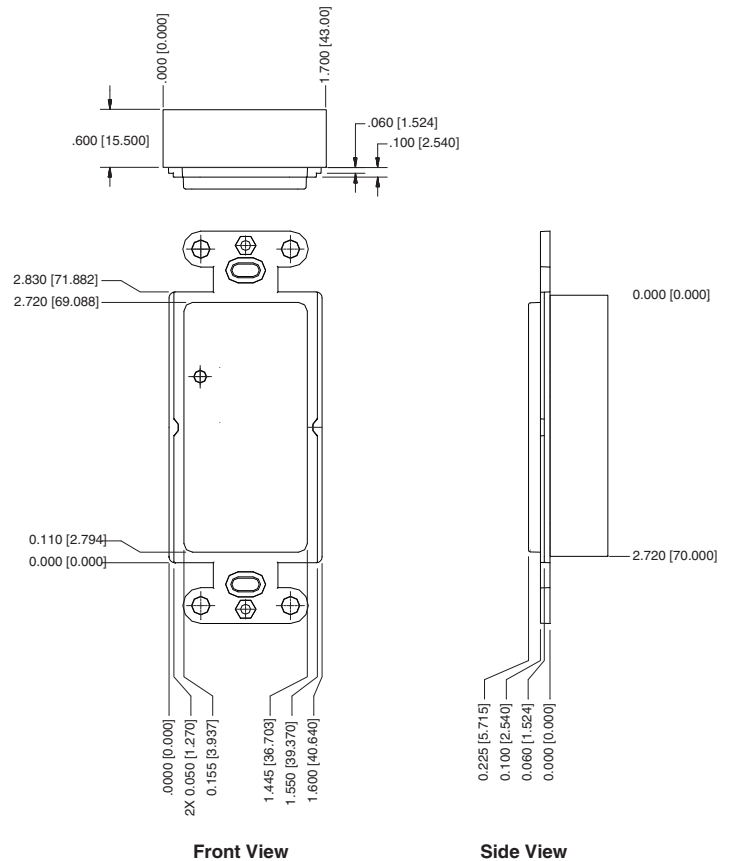

Front View

Side View

D model faceplate dimensions

Parts and Accessories

Included Parts

The table below lists part numbers of the various models.

Model	Part number
P/2 DA2 WM F (black, white, RAL9010 white)	60-376- (-02, -03, -05)
P/2 DA2 EC F (RAL9010 white)	60-376-10
P/2 DA2 WM F AAP (black, white, RAL9010 white)	60-377- (-02, -03, -05)
P/2 DA2 WM EC F AAP (RAL9010 white)	60-377-10
P/2 DA2 D (black, white)	60-955- (-02, -03)
User manual	

Cables

The table below lists various lengths of high resolution VGA cables which can be used with the P/2 DA2 WM F/WM F AAP/EC F/D models.

Male-to-female VGA cables	Part number
VGA 6' MHR	26-238-01
VGA 3' MHR A (with audio)	26-490-01
VGA 6' MHR A (with audio)	26-490-02
VGA 12' MHR A (with audio)	26-490-03
VGA 25' MHR A (with audio)	26-490-04
VGA 50' MHR A (with audio)	26-490-05

Mud ring mounting brackets

The table below lists various mud ring mounting brackets.

MR Series mud ring brackets	Part number
MR 100, 1-gang, black or white	70-519-12 or -13
MR 100D, 1-gang, Decora [®] , black	70-581-12
MR 200, 2-gang, black or white	70-519-22 or -23

Optional architectural adapter plates

A variety of optional adapter plates for pass-through connections may be ordered for the P/2 DA2 WM F AAP and P/2 DA2 WM F AAP EC. See the figure below. The WM F AAP model can accommodate up to four adapter plates and the WM F AAP EC model can handle up to three adapter plates. The adapter plates come in one and two-high sizes.

The WM F AAP model may be configured as follows:

- 4 adapter plates of plate size one *or*
- 2 adapter plates of plate size two *or*
- 2 adapter plates of plate size one and one adapter plate of plate size two

The WM F AAP EC model may be configured as follows:

- 3 adapter plates of plate size one *or*
- 1 adapter plate of plate size two and 1 adapter plate of plate size one

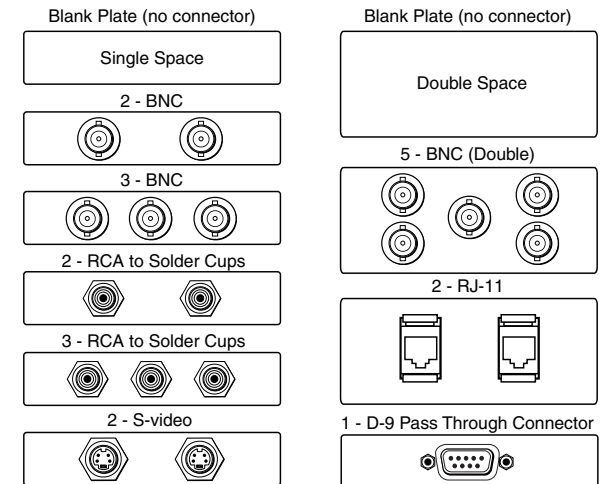

Examples of adapter plates

The tables on following pages list the available adapter plates and distinguish between plates with a single type of connector (single type) or plates with more than one type of connector (multi type).

Single Type Connector Architectural Adapter Plates							
Adapter plate description	Plate size	Front connector type	Rear connector type	Part #	Gray	Black	White
Blank plate 1	1	n.a.	n.a.	70-090	-01	-11	-21
Blank plate 2	2	n.a.	n.a.	70-090	-02	-12	-22
2 BNC barrel (female to female)	1	BNC female	BNC female	70-091	-01	-11	-21
3 BNC barrel (female to female)	1	BNC female	BNC female	70-091	-02	-12	-22
5 BNC barrel (female to female)	2	BNC female	BNC female	70-091	-03	-13	-23
2 RCA female to solder cups	1	RCA female (red/black)	solder lug terminals	70-092	-01	-11	-21
3 RCA female to solder cups	1	RCA female (red/black)	solder lug terminals	70-092	-02	-12	-22
2 RCA female barrel (female to female)	1	RCA female (red/black)	RCA female	70-093	-01	-11	-21
3 RCA female barrel (female to female)	1	RCA female (red/black)	RCA female	70-093	-02	-12	-22
2 RCA to BNC barrel (female to female)	1	RCA female (red/black)	BNC female	70-094	-01	-11	-21
3 RCA to BNC barrel (female to female)	1	RCA female (red/black)	BNC female	70-094	-02	-12	-22
2 S-video to S-video barrel (female to female)	1	4-pin mini DIN female	4-pin mini DIN female	70-095	-01	-11	-21

2 F connector barrel	1	F connector female	F connector female	70-096	-01	-11	-21
(2) ¼" stereo phono female	1	¼" stereo phono female	3 solder lug terminals	70-097	-01	-11	-21
(2) ¼" mono phono female	1	¼" mono phono female	2 solder lug terminals	70-097	-02	-12	-22
(2) 3.5 mm mini stereo female	1	3.5 mm mini stereo female	3 solder lug terminals	70-098	-01	-11	-21
2 RJ-11 (female to female)	2	RJ-11 female	RJ-11 female	70-099	-01	-11	-21
2 RJ-45 (female to female)	2	RJ-45 female	RJ-45 female	70-100	-01	-11	-21
1 HD-15 (female to female)	1	15-pin HD female	15-pin HD female	70-101	-01	-11	-21
1 HD-15 (male to male)	1	15-pin HD male	15-pin HD male	70-101	-02	-12	-22
1 D-9 (female to female)	1	9-pin D female	9-pin D female	70-102	-01	-11	-21
1 D-9 (male to male)	1	9-pin D male	9-pin D male	70-102	-02	-12	-22
(1) 3-pin XLR female	2	3-pin XLR female	3 solder lug terminals	70-103	-01	-11	-21
(1) 4-pin XLR female	2	4-pin XLR female	3 solder lug terminals	70-103	-02	-12	-22
(1) 6-pin XLR female	2	6-pin XLR female	3 solder lug terminals	70-103	-03	-13	-23
(2) 6-pin mini DIN (keyboard/mouse)	1	6-pin mini DIN female	6-pin mini DIN female	70-104	-01	-11	-21
(1) 3.5 mm, 5 pole captive screw terminal	1	3.5 mm, 5 pole captive screw terminal	solder cups	70-105	-01	-11	-21
1 contact closure switch/LED show-me and 3.5 mm stereo mini jack	1	contact closure switch and 3.5 mm mini stereo jack	solder cups	70-106	-01	-11	-21

Multi Type Connector Architectural Adapter Plates							
Adapter plate description	Plate size	Front connector type	Rear connector type	Part #	Gray	Black	White
1 S-video female and 1 BNC female	1	4-pin mini DIN female and BNC female	4-pin mini DIN female and BNC female	70-107	-01	-02	-03
1 S-video female and 3 RCA female	2	4-pin mini DIN female and RCA female	4-pin mini DIN female and RCA female	70-107	-02	-12	-22
1 S-video female and 2 RCA female	1	4-pin mini DIN female and RCA female	4-pin mini DIN female and RCA female	70-107	-03	-13	-23
1 BNC female and 2 RCA female	1	BNC female and RCA female	BNC female and RCA female	70-108	-01	-11	-21
1 BNC female and (1) 3.5 mm mini stereo jack	1	BNC female and 3.5 mm mini stereo jack	BNC female and 3 solder cups	70-108	-02	-12	-22
1 RCA female and (1) 3.5 mm mini stereo jack	1	RCA female and 3.5 mm mini stereo jack	RCA female and 3 solder cups	70-109	-01	-02	-03

Templates

Use these templates as a guide for cutting the hole in the installation surface (wall or furniture).

NOTE This templates for the P/2 DA2 WM F and the P/2 DA 2 WM F AAP are *not* full size. Do not scale.

P/2 DA2 WM F mounting template

Cut-Out Template for Extron's

P/2 DA2 WM F

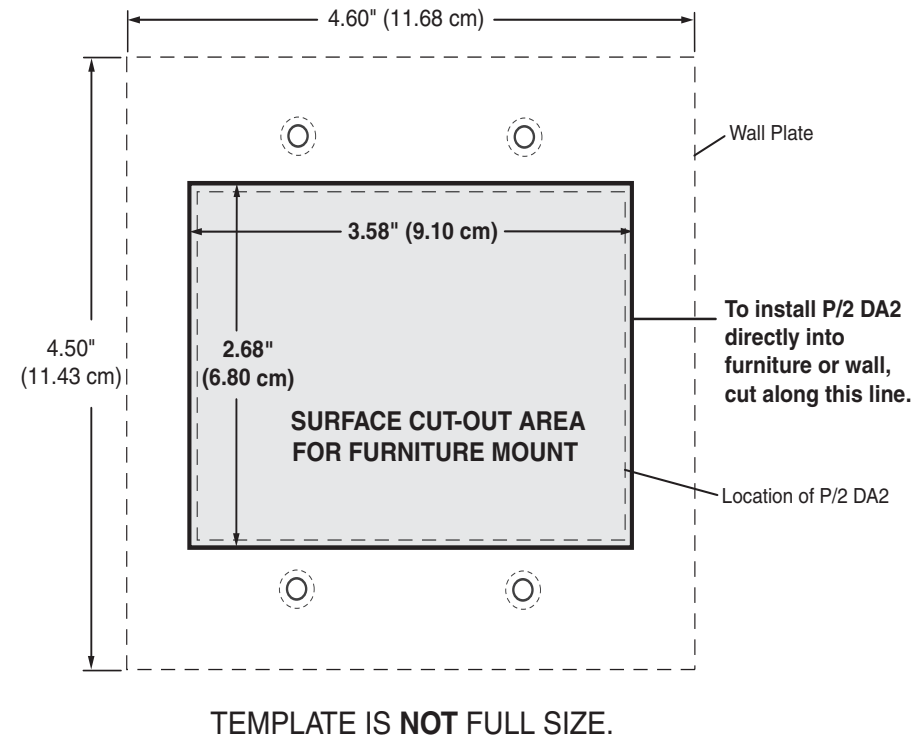

P/2 DA2 WM F AAP mounting template

Cut-Out Template for Extron's

P/2 DA2 WM F AAP

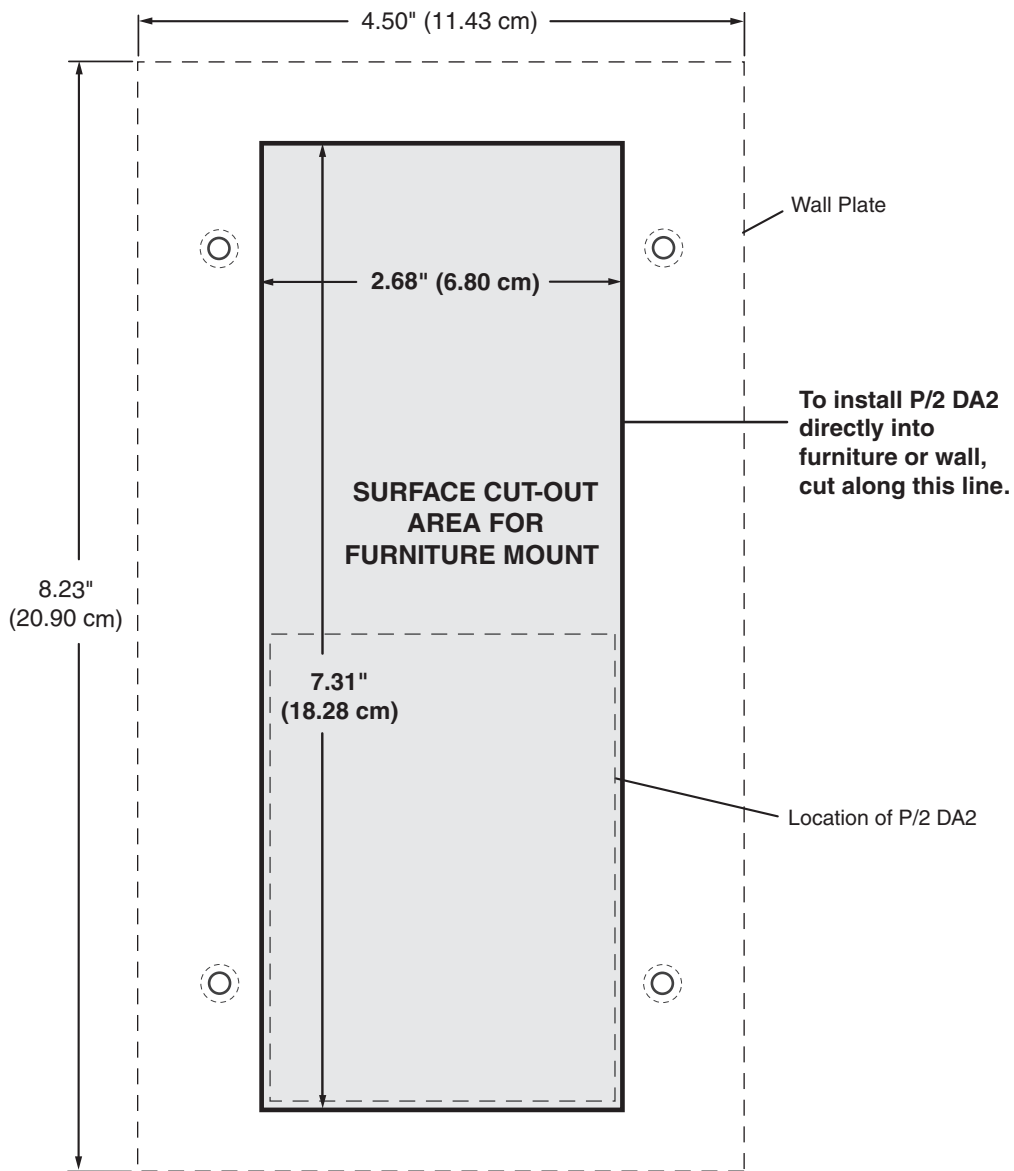

TEMPLATE IS **NOT** FULL SIZE.

P/2 DA2 D mounting template

Cut-Out Template for Extron's

P/2 DA2 D

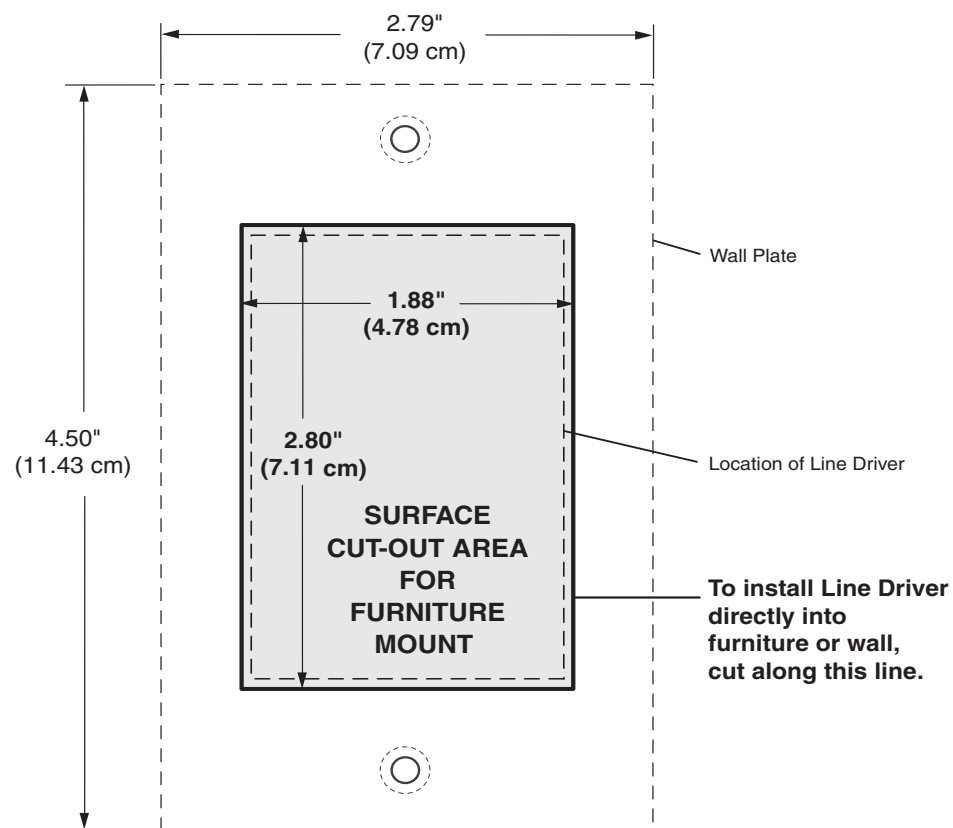

TEMPLATE IS FULL SIZE.

Please measure the printed template before cutting.

Specifications, Dimensions, and Parts, cont'd